



Illustrated Parts List

Pressure Washer / Lavadora de Presión



This pressure washer is rated in accordance to the Pressure Washer Manufacture Association (PWMA) Standard PW101 (Testing and Rating Performance of Pressure Washers).

Questions? Help is just a moment away!
Preguntas? La ayuda es justa un momento lejos!
Call: Pressure Washer Helpline

Llame: Línea Directa del Lavadora a Presión - 1-800-743-4115 M-F 8-5 CT

Model / Modelo

| Mfg. No. | Description / Descripción |
|-----------------|----------------------------------|
| 020461-0 | 2,500 PSI Briggs & Stratton |

Manual Part No. 314918

Revision B

Rev. Date: 12/9/2011

Not for
Reproduction

| PRODUCT COMPONENTS | PAGES |
|---|--------------------------|
| Main Unit | 4 |
| Pump | 6 |
| Torque Specification Chart | Inside Back Cover |

Not for
Reproduction

Main Unit

313729

NOTE: Unless noted otherwise,
use the standard hardware torque
specification chart.

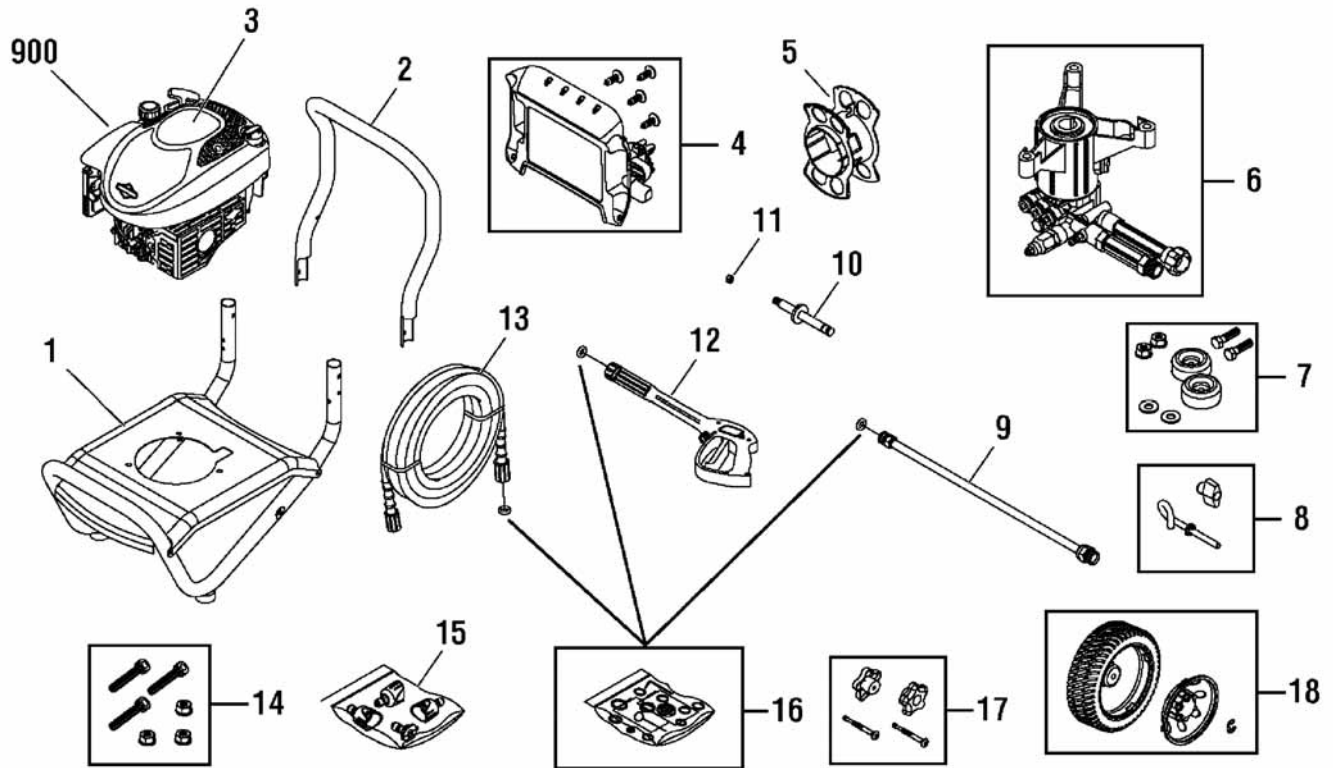

| REF. | PART NO. | DESCRIPTION | REF. | PART NO. | DESCRIPTION |
|------|------------|------------------------------|------|------------|------------------------------------|
| 1 | 313617GS | BASE | -- | 201580XGS | NOZZLE, QC Orange |
| 2 | 204257BRGS | HANDLE | -- | 201580AAGS | NOZZLE, QC Red |
| 3 | 208325GS | DECAL | -- | 198841GS | NOZZLE, QC Black |
| 4 | 313674GS | BILLBOARD | 16 | 196002GS | KIT, O-Rings |
| -- | B1797GS | CLIP | 17 | 205910GS | KIT, Hardware, Handle |
| 5 | 204684GS | WRAP, Hose | 18 | 209568GS | KIT, Wheel |
| 6 | 202274GS | PUMP | -- | 192050GS | HUBCAP |
| 7 | 192310GS | MOUNT, Vibration | -- | 200520GS | E-RING |
| 8 | 205912GS | GUIDE, Rope | 900 | ---- | * ENGINE |
| 9 | 207784GS | EXTENSION, QC | -- | 313681GS | MANUAL, Operator (Not Illustrated) |
| 10 | 313032GS | AXLE | -- | 200672GS | DECAL, Caution (Not Illustrated) |
| 11 | 015X68MA | NUT | -- | 189332GS | PLUG, Hole (Not Illustrated) |
| 12 | 204627GS | GUN | -- | 23139GS | KEY (Not Illustrated) |
| 13 | 202017GS | HOSE | -- | 199272GS | AXLE (Not Illustrated) |
| 14 | 203526GS | KIT, Hardware, Pump Mounting | -- | 310975GS | HOSE, Chemical (Not Illustrated) |
| 15 | 202182GS | KIT, QC Nozzles | -- | 195015GS | TAG, Warning (Not Illustrated) |
| -- | 201580RGS | NOZZLE, QC Yellow | | | |

Footnotes

*Contact Engine Manufacturer for parts and service.

The above parts group applies to the following Mfg. Nos.:

020461-0 - 2,500 PSI Briggs & Stratton

Main Unit

313729

NOTE: Unless noted otherwise,
use the standard hardware torque
specification chart.

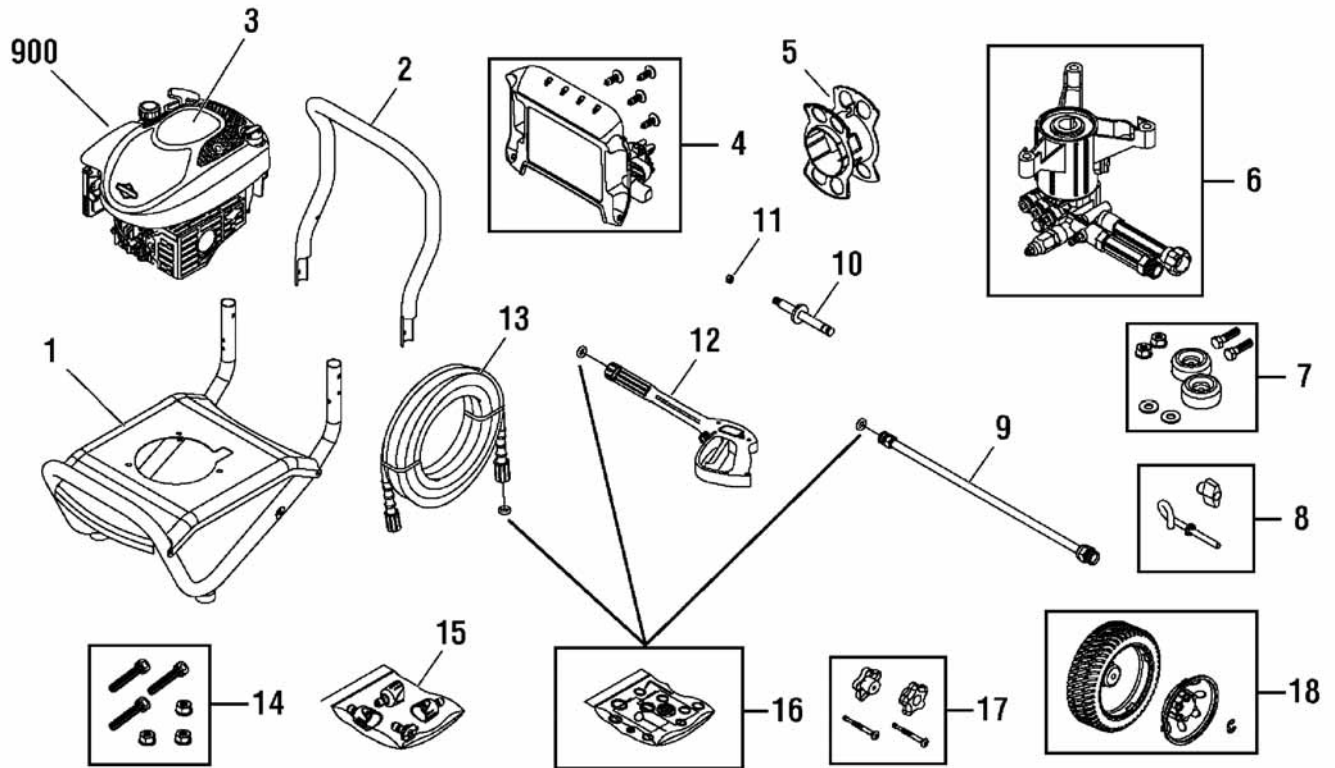

| REF. PART NO. | DESCRIPTION | REF. PART NO. | DESCRIPTION |
|---------------|---|---------------|-------------|
| -- 6039 | PUMP SAVER (Optional Accessory, Not Included) | | |

Footnotes

*Contact Engine Manufacturer for parts and service.

The above parts group applies to the following Mfg. Nos.:

020461-0 - 2,500 PSI Briggs & Stratton

Pump

201112SRV

NOTE: Unless noted otherwise, use the standard hardware torque specification chart.

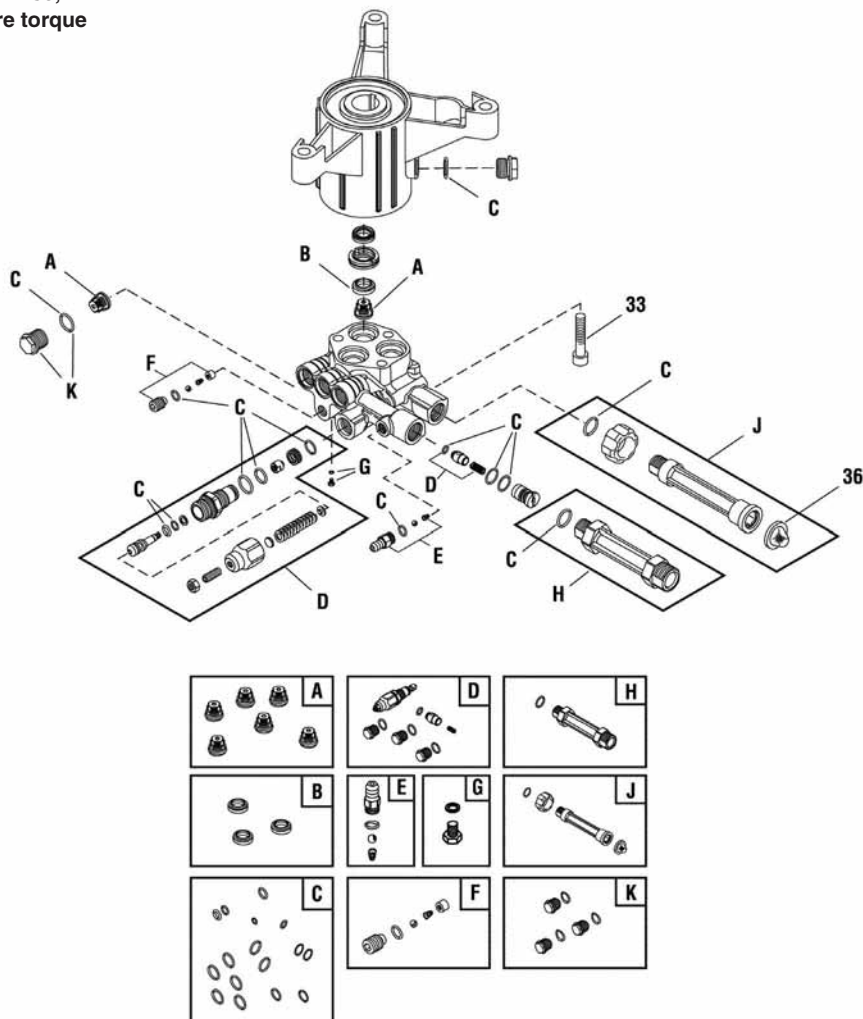

| REF. | PART NO. | DESCRIPTION | REF. | PART NO. | DESCRIPTION |
|------|----------|--|------|----------|-------------|
| 33 | 200275GS | SCREW | | | |
| 36 | B2384GS | FILTER, Garden Hose | | | |
| A | 200344GS | * KIT, Check Valve | | | |
| B | 200345GS | * KIT, Water Seal | | | |
| C | 200346GS | * KIT, O-Ring | | | |
| D | 315747GS | * KIT, Unloader | | | |
| E | 192914GS | * KIT, Chemical Injection | | | |
| F | 200349GS | * KIT, Easy Start | | | |
| G | 200350GS | * SCREW, Grub | | | |
| H | 201497GS | * FITTING | | | |
| J | 201496GS | * KIT, Water Inlet | | | |
| K | 317056GS | * KIT, Plug | | | |
| -- | 208673GS | VALVE, Thermo Relief (Not Illustrated) | | | |
| -- | 6039 | PUMP SAVER (Optional Accessory) | | | |
| -- | 6033 | OIL BOTTLE (Optional Accessory) | | | |

Footnotes

* Service Kit includes all parts shown in box.

The above parts group applies to the following Mfg. Nos.:

020461-0 - 2,500 PSI Briggs & Stratton

Hardware Identification & Torque Specifications

| Torque Specification Chart | | | | | | | | |
|--|-----------|------|-----------|------|------------|------|------------|------|
| FOR STANDARD METRIC MACHINE HARDWARE (Tolerance ± 20%) | | | | | | | | |
| Property Class | 5.6 | | 8.8 | | 10.9 | | 12.9 | |
| | Class 5.6 | | Class 8.8 | | Class 10.9 | | Class 12.9 | |
| Size Of Hardware | in/lbs | | in/lbs | | in/lbs | | in/lbs | |
| | ft/lbs | Nm. | ft/lbs | Nm. | ft/lbs | Nm. | ft/lbs | Nm. |
| M3 | 5.88 | .56 | 13.44 | 1.28 | 19.2 | 1.80 | 22.92 | 2.15 |
| M4 | 13.44 | 1.28 | 30.72 | 2.90 | 43.44 | 4.10 | 52.56 | 4.95 |
| M5 | 26.4 | 2.50 | 60.96 | 5.75 | 5.97 | 8.10 | 7.15 | 9.7 |
| M6 | 44.64 | 4.3 | 7.3 | 9.9 | 10.3 | 14 | 12.1 | 16.5 |
| M7 | 5.2 | 7.1 | 12.1 | 16.5 | 16.9 | 23 | 19.9 | 27 |
| M8 | 7.7 | 10.5 | 17.7 | 24 | 25 | 34 | 29 | 40 |
| M10 | 15 | 21 | 35 | 48 | 50 | 67 | 59 | 81 |
| M12 | 26 | 36 | 61 | 83 | 86.2 | 117 | 103 | 140 |
| M14 | 42 | 58 | 101 | 132 | 136 | 185 | 162 | 220 |
| M16 | 64 | 88 | 147 | 200 | 210 | 285 | 250 | 340 |
| M18 | 89 | 121 | 202 | 275 | 287 | 390 | 346 | 470 |
| M20 | 126 | 171 | 290 | 390 | 405 | 550 | 486 | 660 |
| M22 | 169 | 230 | 390 | 530 | 559 | 745 | 656 | 890 |
| M24 | 217 | 295 | 497 | 375 | 708 | 960 | 840 | 1140 |
| M27 | 320 | 435 | 733 | 995 | 1032 | 1400 | 1239 | 1680 |
| M30 | 435 | 590 | 995 | 1350 | 1401 | 1900 | 1681 | 2280 |
| M33 | 590 | 800 | 1349 | 1830 | 1902 | 2580 | 2278 | 3090 |
| M36 | 759 | 1030 | 1740 | 2360 | 2441 | 3310 | 2935 | 3980 |
| M39 | 988 | 1340 | 2249 | 3050 | 3163 | 4290 | 3798 | 5150 |

The guides and ruler furnished below are designed to help you select the appropriate hardware.



Nut, M8

Thread Diameter (mm)
Inside Diameter (in)
Threads per inch

Nut, 1/2-16

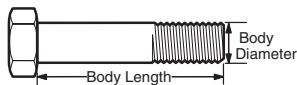

Screw, M8- 1.25 x 25

Thread Diameter (mm)
Body Diameter
Distance between threads (mm)
Threads per inch
Body Length (mm)
Body Length (in)

Screw, 1/2- 16 x 2

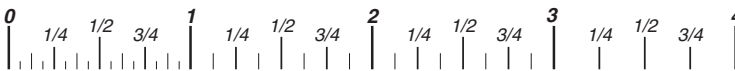

Standard Hardware Sizing

When a washer or nut is identified as 1/2" (M8), this is the *Nominal size*, meaning the *inside diameter* is 1/2 inch (8mm metric thread diameter); if a second number is present it represents the *threads per inch* (distance between threads).

When bolt or capscrew is identified as 1/2 - 16 x 2" (M8 - 1.25 x 50), this means the *Nominal size*, or body diameter is 1/2 inch (8mm metric thread diameter), the second number, 16, represents the *threads per inch*, (1.25 thread diameter). The final number is the body length of the bolt or screw, 2 inches (50mm).

| Torque Specification Chart | | | | | | |
|---|-------------|-------|-------------|-------|-------------|---------|
| FOR STANDARD MACHINE HARDWARE (Tolerance ± 20%) | | | | | | |
| Hardware Grade | No Marks | | SAE Grade 5 | | SAE Grade 8 | |
| | SAE Grade 2 | | SAE Grade 5 | | SAE Grade 8 | |
| Size Of Hardware | in/lbs | | in/lbs | | in/lbs | |
| | ft/lbs | Nm. | ft/lbs | Nm. | ft/lbs | Nm. |
| 8-32 | 19 | 2.1 | 30 | 3.4 | 41 | 4.6 |
| 8-36 | 20 | 2.3 | 31 | 3.5 | 43 | 4.9 |
| 10-24 | 27 | 3.1 | 43 | 4.9 | 60 | 6.8 |
| 10-32 | 31 | 3.5 | 49 | 5.5 | 68 | 7.7 |
| 1/4-20 | 66 | 7.6 | 8 | 10.9 | 12 | 16.3 |
| 1/4-28 | 76 | 8.6 | 10 | 13.6 | 14 | 19.0 |
| 5/16-18 | 11 | 15.0 | 17 | 23.1 | 25 | 34.0 |
| 5/16-24 | 12 | 16.3 | 19 | 25.8 | 29 | 34.0 |
| 3/8-16 | 20 | 27.2 | 30 | 40.8 | 45 | 61.2 |
| 3/8-24 | 23 | 31.3 | 35 | 47.6 | 50 | 68.0 |
| 7/16-14 | 30 | 40.8 | 50 | 68.0 | 70 | 95.2 |
| 7/16-20 | 35 | 47.6 | 55 | 74.8 | 80 | 108.8 |
| 1/2-13 | 50 | 68.0 | 75 | 102.0 | 110 | 149.6 |
| 1/2-20 | 55 | 74.8 | 90 | 122.4 | 120 | 163.2 |
| 9/16-12 | 65 | 88.4 | 110 | 149.6 | 150 | 204.0 |
| 9/16-18 | 75 | 102.0 | 120 | 163.2 | 170 | 231.2 |
| 5/8-11 | 90 | 122.4 | 150 | 204.0 | 220 | 299.2 |
| 5/8-18 | 100 | 136 | 180 | 244.8 | 240 | 326.4 |
| 3/4-10 | 160 | 217.6 | 260 | 353.6 | 386 | 525.0 |
| 3/4-16 | 180 | 244.8 | 300 | 408.0 | 420 | 571.2 |
| 7/8-9 | 140 | 190.4 | 400 | 544.0 | 600 | 816.0 |
| 7/8-14 | 155 | 210.8 | 440 | 598.4 | 660 | 897.6 |
| 1-8 | 220 | 299.2 | 580 | 788.8 | 900 | 1,244.0 |
| 1-12 | 240 | 326.4 | 640 | 870.4 | 1,000 | 1,360.0 |

NOTES

- These torque values are to be used for all hardware excluding: locknuts, self-tapping screws, thread forming screws, sheet metal screws and socket head setscrews.
- Recommended seating torque values for locknuts:
 - for prevailing torque locknuts - use 65% of grade 5 torques.
 - for flange whizlock nuts and screws - use 135% of grade 5 torques.
- Unless otherwise noted on assembly drawings, all torque values must meet this specification.

Common Hardware Types

Hex Head Capscrew



Washer



Carriage Bolt



Hex Nut

Wrench & Fastener Size Guide

| | | | | |
|----------------------------------|----------------------------------|----------------------------------|--|---------------------------------|
| | | | | |
| 1/4" Bolt or Nut Wrench—7/16" | 5/16" Bolt or Nut Wrench—1/2" | 3/8" Bolt or Nut Wrench—9/16" | 7/16" Bolt or Nut Wrench (Bolt)—5/8" Wrench (Nut)—11/16" | 1/2" Bolt or Nut Wrench—3/4" |
| M6 Bolt or Nut Wrench—10mm | M8 Bolt or Nut Wrench—13mm | M10 Bolt or Nut Wrench—17mm | M12 Bolt or Nut Wrench—19mm | M14 Bolt or Nut Wrench—22mm |



Not for
Reproduction

Briggs & Stratton Power Products Group, LLC

Copyright© 2011 Briggs & Stratton Power Products Group, LLC. All rights reserved. No part of this page can be reproduced or transmitted in any form by any means without the express written permission of Briggs & Stratton Power Products Group, LLC.